

EDI ENTERPRISE PVT. LTD.

EDI Enterprise Pvt. Ltd. Is an Integrative Company offering wide range of Engineering Solutions and Design Service to their Clients.

Industry Verticals We Serves In:

- Fertilizers – NPK, Urea, GSSP
- Chemicals
- Petrochemicals
- Grains & DOC
- Sugar
- Plastics & Polymers



Powder



Granules



Flakes



Animal Feed

→WEIGHING & BAGGING → CONVEYORS → BATCH AUTOMATION → HIGH STANDARD ENGINEERING
 → RELIABLE PRODUCTS → NEW PRODUCT DEVELOPMENT → TURNKEY MATERIAL HANDLING
 SOLUTIONS → PLANT LAYOUT DESIGNING → 3D MODELING → REVERSE ENGINEERING → INDUSTRIAL
 AUTOMATION → WORK CONTRACT SERVICES

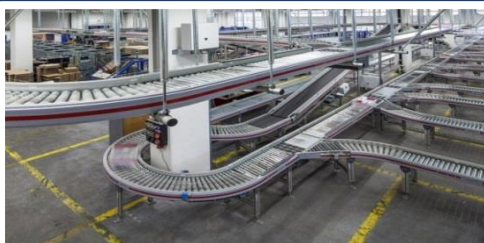

EDI

EDI ENTERPRISE PVT. LTD.

www.engineersdesignindia.in Email- sales@engineersdesignindia.in

Contact Details: +91-9953505647; +91-9560118330;

WEIGHING & BAGGING MACHINE

EDI Machines are designed and manufactured adopting the latest technological developments in the field of accurate weighing. The weighing and bagging machines are available in different models .

EGW0305

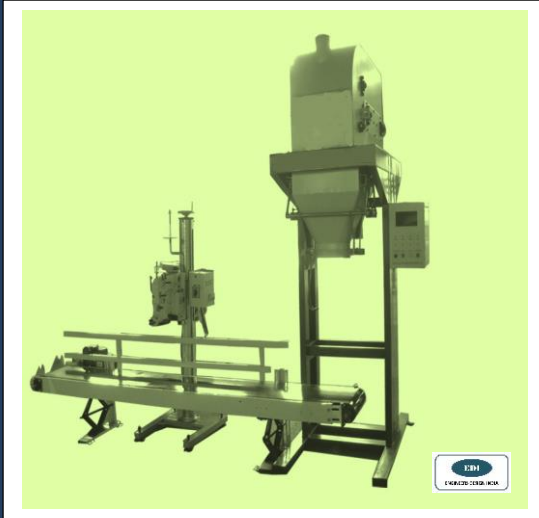

EBM1518



Type	Gross Feeding
Bag Capacity	20 – 50 KG
Duty	240 Bags/Hour
Accuracy	20 gm/sigma
Feeding Arrangement	Gravity
Filling Speed	Two Speed, Major and Dribble
Air Supply Pressure	6.0 Kg/Cm2

E D I E N T E R P R I S E	Type	Net Feeding
	Bag Capacity	20 – 70 KG
	Duty	1080 Bags/Hour
	Accuracy	20 gm/sigma
	Feeding Arrangement	Gravity
	Filling Speed	Two Speed, Major and Dribble
	Air Supply Pressure	6.0 Kg/Cm2

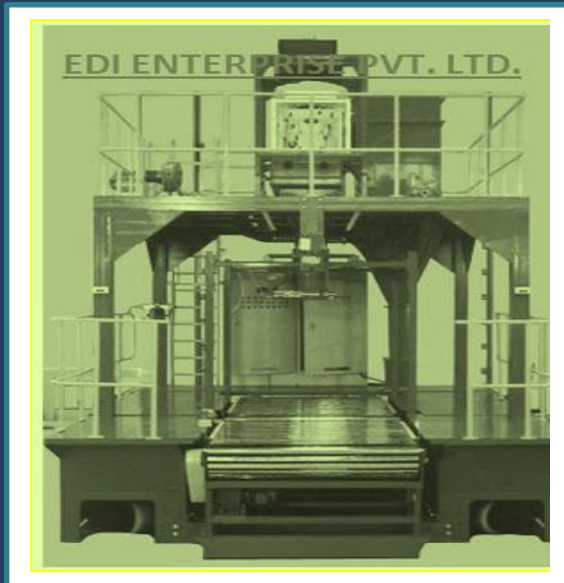

EBMJ1T

Type	Jumbo Bagging
Bag Capacity	500 KG to 2000 KG
Duty	10 Bags/Hour
Accuracy	100 gm/sigma
Feeding Arrangement	Gravity
Filling Speed	Two Speed, Major and Dribble
System Operating Voltage	230V AC, 1 PH , 50 Hz 415V AC, 3 PH, 50 Hz
Air Supply Pressure	6.0 Kg/Cm2
Air Consumption	20 Litres of Free Air/Working Cycle

Note: Bagging Rate & Accuracy depends upon bulk density, flow characteristics of the product.

ED09-Controller

Parameters	Details
Load Cell Excitation Voltage	5VDC
Load Cell Capacity	8 x 350 Ohm
A/D Conversion	24 Bit Sigma-Delta
Sampling Frequency	1600 samples/sec
Filter	Yes
Display Resolution	1 gm
Digital I/O	8 x 8 Isolated PNP, NPN, fully customised
Power Supply	24 VDC/230 VAC
Communication Ports	Inbuilt RS232, RS422,RS485, Ethernet,CanBus, USB, with universal in built Protocols.
Display	5.7 inch Coloured, fully touch screen
Software	Display, I/O's, Interlock, Buttons,etc all fully customised
Memory Backup	10 years without Power Supply



Salient Features of Controller

- Color Touch Screen with soft touch buttons on RUN page.
- Auto tare in each weightment.
- Auto Inflight correction for each bag.
- Emergency/ Pause Availability
- In built Troubleshooting guide.

COMPLETE INTEGRATED BAGGING LINE



The EDI solutions include several Products that can reduce labor and save time. Our Solutions can be easily adapted to existing plant layouts.

All EDI bagging and palletizing systems can be integrated into existing plant data acquisition systems for quality control and packaging efficiency control.

The modular design allows an easy upgrade of machine performance to be made without the need to replace the complete system. We prove our skill and competence at all bulk materials handling and processing stages.

EDI is not just any other Company, we are friend with a solution, to your problems.

EDI POUCH PACKING SOLUTIONS:

EDI is a one stop solution provider for all flexible packing materials needs that includes food packing material, agricultural packing material and many more. With the leading expertise of professionals, we are involved in the manufacturing and supplying high quality Pouch Packaging Machine.

EATPPM40



Packing Range	20gm to 1 KG
Filling System	Servo Auger Filler
Type of Sealing	Center Sealing
Film Size	100mm – 450mm width x 100mm – 250mm Length
Film Roll Size	OD 250 to 300mm max ID film reel pipe 75mm min.
Speed	40 – 80 pouch/min as per material characteristics
Optional	Batch Coding Device, Batch Cutting Device GMP Model, Level Sensor
Machine Weight	750 Kg (Approx)
Motor	Motor 0.5 HP
Power Consumption	220 V AC Single Phase
Heater	150*2 + 300*2

EDI Pouch Packing Models:

- Fully Automatic Auger Type Pouch Packing (50 -500 gm)
(Model EATPPM40)
- Liquid Pouch Packing Machine
(Model-ELPPM100)
- Biscuit Packing Machine
(Model-EBPM100)
- Detergent Packing Machine
(Model-EDPM100)

EDI is offering Servo Auger type pouch Packaging, Collar Type Auger Filler Pouch, Liquid Pouch Packing, Biscuit Packing, Detergent Packing. We manufactured these machines and plants using high grade steel to ensure quality of our end products. These machinery and plants are extensively used for various applications in diverse industries such as food and pulp, bottling unit and other allied industries.

Furthermore, to serve our clients in efficient manner, we are also capable to offer excellent after sales services. It is offered in order to enhance the functionality quality, durability and performance of the machines, which was earlier nonexistence in the market.

It is all because of availability of Service Engineers at all major location across the India, which are ready to serve you at one call.

EDI AUTOMATIC BAG PLACER

MODEL – EBPM600

EBPM600 unique bag placing system transfers Bags from a flat belt conveyor to the Bag Placer.

This Bag Placement method yields a reliable, repeatable position of the bag for the faster fill rate. The Bag Placing system easily handles 20 Kg to 50 Kg bags with minimal adjustments required to switch between sizes. It is designed to be used in the conjunction with EBM1518 Bagging Machine, yet is versatile enough to use with other types of Bag Filling Systems.

EBPM600 is designed for ruggedness, yet is very simple and clean in appearance. It is designed with few moving parts which reduces maintenance and wear on the machine and minimizes weight for faster cycling time.



CAPACITY	600 BAGS PER HOUR
PRODUCT WEIGHT	20 Kg to 50 Kg
KIND OF BAG	Multiwall paper bag, including woven laminated paper.
TYPE of BAG	Open Mouth Paper Bag, HDPE Bags
BAG SIZE	650-950(L) x 350-470(W)
BAG MAGZINE	Max 250 Bags
VACUUM EQUIPMENT	Vacuum Generator
COMPRESSED AIR	6 Bar
POWER SOURCE	Single Phase



OUR NETWORK



Integrated Solutions:



EDI Enterprise Pvt. Ltd.

AN INTEGRATIVE COMPANY OFFERING WIDE RANGE OF SOLUTIONS

-  **EDI WEIGHING & BAGGING**
-  **EDI POUCH PACKING SOLUTIONS**
-  **EDI AUTOMATION & LABOR SAVING**
-  **EDI WORK LABOR CONTRACT SERVICES**
-  **EDI TURNKEY SOLUTIONS**



BIN ACTIVATOR



BAG DIVERTER



TWIN SCREW



ROTARY AIR LOCK



METAL DETECTOR



TRUCK LOADER



STITCHING MACHINE



STACKER



PORTABLE CONVEYOR



WAGON LOADER